

## AWWA C503 Wet-Barrel Fire Hydrant (SSZ)

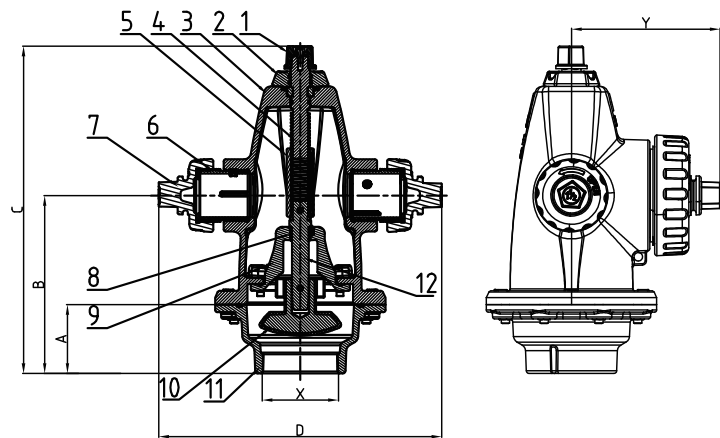

SSZ

- Design Standard: AWWA C503-2014
- Working Pressure: 300PSI
- Temperature Range: 0°C - 80°C
- Coating: Fusion Bonded Epoxy Coating in accordance with ANSI/AWWA C550



### MATERIAL SPECIFICATION

Part No.	Part	Standard Specification	Options
1	Stem Cap	ASTM A536, 65-45-12	
2	Gland	ASTM A536, 65-45-12	
3	Body	ASTM A536, 65-45-12	
4	Upper Stem	AISI 420	AISI 431
5	Stem Nut	C95400	
6	Nozzle	C83600	
7	Nozzle Cap	ASTM A536, 65-45-12	
8	Stem Ferrule	C83600	
9	Seat	ASTM A536, 65-45-12	
10	Clapper	ASTM A536, 65-45-12 + EPDM	ASTM A536, 65-45-12 + NBR
11	Lower Body	ASTM A536, 65-45-12	
12	Lower Stem	AISI 420	AISI 431

Note: For special material request other than standard specification, please indicate clearly on the inquiry or order list.

DN		Dimensions(mm)					
Inch	mm	A	B	C	D	X	Y
4"	100	101	261.1	480.2	415.5	4-8NPT	220